

XJP30D - XJP60D**ACQUISITION MODULES****INDEX**

1. GENERAL WARNING	1
2. GENERAL DESCRIPTION	1
3. MODELS	1
4. PROGRAMMING KEYBOARD (KB1 PRG)	1
5. SECTION MENU	2
6. SECTION PARAMETERS PROGRAMMING	2
7. COPY FUNCTION	2
8. SERIAL SETTING	2
9. LIST OF PARAMETERS	2
10. XJP-REP & KB1 PRG & HOT KEY	2
11. INSTALLATION AND MOUNTING	3
12. ELECTRICAL CONNECTIONS	3
13. SERIAL COMMUNICATION	3
14. TECHNICAL DATA	3
15. CONNECTIONS	3
16. DEFAULT SETTING VALUES	4

1. GENERAL WARNING**1.1 PLEASE READ BEFORE USING THIS MANUAL**

- This manual is part of the product and should be kept near the instrument for easy and quick reference.
- The instrument shall not be used for purposes different from those described hereunder. It cannot be used as a safety device.
- Check the application limits before proceeding.

1.2 SAFETY PRECAUTIONS

- Check the supply voltage is correct before connecting the instrument.
- Do not expose to water or moisture; use the controller only within the operating limits avoiding sudden temperature changes with high atmospheric humidity to prevent formation of condensation
- Warning: disconnect all electrical connections before any kind of maintenance.
- Fit the probe where it is not accessible by the End User. The instrument must not be opened.
- In case of failure or faulty operation send the instrument back to the distributor or to "Dixell s.r.l." (see address) with a detailed description of the fault.
- Consider the maximum current which can be applied to each relay (see Technical Data).
- Ensure that the wires for probes, loads and the power supply are separated and far enough from each other, without crossing or intertwining.
- In case of applications in industrial environments, the use of mains filters (our mod. FT1) in parallel with inductive loads could be useful.

2. GENERAL DESCRIPTION

XJP30D and **XJP60D** are acquisition modules that can read up to 6 analogue inputs and 3 inputs at 230Vac(110Vac or 24Vac opt.). By means of the serial output RS485, they can be connected to the XJ500 or a ModBUS-RTU compatible monitoring system. Modules **XJP**, DIN RAIL format, are without display and are programmable by means of a programming keyboard **KB1 PRG**. The analogue inputs can be PTC, NTC 4+20mA or 0-10V; when the inputs are PTC or NTC the choice can be made by a parameter.

It is also possible to program them with a programming "Hot key" and to connect them to a display device called **XJP REP** which shows the main temperature and input status.

3. MODELS

XJP modules can have different serial addresses; a "Section" corresponds to each address. An instrument can have up to 6 section inputs, that is, it can be separated into 6 different parts, each one with different serial addresses and a completely independent parameter list.

Each section can have different configurations. The first three measurement inputs are always associated to three power supply inputs and the 4-5-6 inputs can be configured through parameters as digital inputs (free voltage) or measurement inputs.

Models	Measurement inputs	Power supply inputs	Digital inputs (free voltage)	Maximum number of sections
XJP30D	3	3	—	3
XJP30D	3	3	3	3
XJP60D	3+3(*)	3	3(*)	6

In **XJP60D**, 3 analogue inputs are configurable by parameter as digital inputs free voltage.

4. PROGRAMMING KEYBOARD (KB1 PRG)

The module programming must be done with programming keyboard **KB1 PRG**.



SET :TO DISPLAY TARGET SET POINT: by pressing and releasing this key the set point is displayed for 5s. In fact this value is not a real set point, but the temperature that must be maintained inside the cold room. In this way from the XJ500, in case of temperature alarms, it is possible to know the Set point too.

TO MODIFY SET POINT: by holding the key pressed for at least 2s, set point change mode is entered: the set point is displayed and the LEDs of the first and third digits blink. To change the value use the ▲ and ▼ keys. The new value can be stored either by pressing the "SET" key (the instrument restores temperature display) or by waiting for the exit time-out to expire (15s).

▲ (UP): In programming mode it browses the parameter codes or increases the displayed value.

▼ (DOWN): In programming mode it browses the parameter codes or decreases the displayed value.

SECTION: Section menu access: By pushing and releasing this button, the section menu is entered. An instrument can have up to 6 sections, that is, it can be separated into 6 different parts, each one with different serial addresses and a completely independent parameter list.

(XJP60 can have up to 6 sections, XJP30 up to 3)

PRG : Display activated section: By pushing and releasing this button, the section name is displayed. **To enter programming mode:** By holding it pressed for 2s, the programming mode is entered.

COPY: In section menu it allows the user to paste the parameter list of the "Work Section" in the desired section. During normal operation it allows "UPLOADING" of the parameter list from the module to the "Hot key".

4.1 USE OF LEDS

On the modules there are three leds:

LED	MODE	Function
Yellow	FLASHING	serial communication is OK
Yellow	ON	the module receives only
Yellow	OFF	serial communication absent
Green	ON	The module is ON
Red	ON	ALARM signal

N.B. There are other possible status of the LEDs. See paragraph related to programming by using the "Hot Key".

4.2 XJP REP DISPLAY

If the "Work section" has a measurement input, the programming keyboard or the **XJP REP** show the input value and the digital input status are displayed by two different leds.

Led ON = Digital input ON
Led OFF = Digital input OFF

If the "Work Section" doesn't have measurement input the programming keyboard or the **XJP REP** show the digital input status according to the following codes :

- If there are non-active inputs and alarms, "nOA" is displayed.
- If there is an active alarm input, "A" + Adr (Serial address) is displayed.
- If there is an active input configured as Status, "S" + Adr (Serial address) is displayed.

5. SECTION MENU

Includes the sections used in the module and the values measured by the inputs.

Access procedure:

- The section menu is entered by pushing and releasing the "Section" key. The label of the first function "Snc" will be displayed.
- The "UP" and "DOWN" keys are used to cycle backwards or forwards in the menu.
- By pressing the "Section" key on the label, the input status will be displayed.
- By pressing the "Section" key again the following section label will be displayed.

5.1 LIST OF FUNCTIONS IN THE SECTION MENU:

- "Snc" Number of sections.
- "Se0" Includes Pb0 probe value and Input 0 operation status.
- "Se1" Includes Pb1 probe value and Input 1 operation status.
- "Se2" Includes Pb2 probe value and Input 2 operation status.
- "Se3" Includes Pb3 probe value or I.D.3 digital input status.
- "Se4" Includes Pb4 probe value or I.D.4 digital input status.
- "Se5" Includes Pb5 probe value or I.D.5 digital input status.
- "Pr1" Includes module general parameters.
- "Out" exits from menu

5.2 HOW TO SET THE NUMBER OF SECTIONS "SNC"

By entering Section menu, the first label "Snc" appears.

- By pressing "Section" key, the number of sections enabled appear. (Default =1)
- By ▲ or ▼ the user modifies the number of sections enabled.
- By pushing "Section" key, the number of sections will be memorised, and the main visualisation will be displayed. (The number of sections blinks for 3 times when the "Section" key is pressed)
- If the number of sections is not modified, by pressing the "Section" key again, label "Se0" will be displayed.

5.3 INPUT STATUS DISPLAY

When the section number setting is executed, a number of "SeX" labels equal to the number of sections programmed will appear in the Section menu.

- By pushing and releasing the "Section" key on the label "SeX", the state of the input is displayed.
- By pushing and releasing the "Section" key, the label of the following section is displayed.
- If no keys are pressed for 10 sec. or "Section" is pressed on the label "Out", the main visualisation will be displayed.

5.4 "WORK SECTION" ACTIVATION

- By pushing the "Section" key for 3 sec. on the label "SeX" in the Section menu, "work section" will be activated. (factory setting Se0).

N.B. It is possible to enter the "work section" parameter list only

5.5 GENERAL PARAMETERS PR1

There are some general parameters common for all the sections. To be able to display and modify them:

- press the "Section" key
- select the label "Pr1" in the Section menu and press "Section".

dAO Delay of temperature alarm at startup: (from 0min to 23h 50min) time interval between the detection of the temperature alarm condition after instrument power on and alarm signalling.

EdA Alarm delay at the end of defrost: (0÷250 min) Time interval between the detection of the temperature alarm condition at the end of defrost and alarm signalling.

Pbc Type of probe: (Ptc = PTC probe; ntc = ntc probe).

rES Resolution (for °C): allows decimal point display. (de = 0,1 °C; in = 1 °C)

CF Temperature measurement unit: (°C= Celsius; °F= Fahrenheit)

Rel Release software: (read only)

Ptb Parameter table: (read only) shows the factory default settings.

5.6 EXIT

If no key is pressed for more than 15 seconds, the instrument reverts to main display mode.

6. SECTION PARAMETERS PROGRAMMING

6.1 TO ENTER THE PARAMETER LIST

To enter the parameter list of the "work section", press PRG key for 2 seconds.

6.2 HOW TO CHANGE THE PARAMETER VALUE

Each parameter is identified by a special alphanumeric code (label).

To change the parameter value, do as follows:

- Enter the "parameter list" by pressing PRG key for 2 sec.
- Browse the parameter list by using "UP" or "DOWN" until the required parameter is displayed.
- Press the "SET" key to display its value.
- Use "UP" or "DOWN" to change its value.
- Press "SET" to store the new value and skip to the following parameter.

TO EXIT: Press "SET" + "UP" or wait 15s without touching any key.

NOTE: the set value is stored. even when the procedure is exited, by waiting the timeout to expire without pressing "SET".

7. COPY FUNCTION

To facilitate module programming operations, it is possible to copy the parameter list from "work section" to another.

- Enter the section menu ("Section" key).
- Browse by using the "UP" and "DOWN" keys, the list of sections until the label of the section to program is displayed.
- By pushing the "COPY" key until the code of the section flashes, the parameter list of the "work section" is pasted in the new one.

8. SERIAL SETTING

In the factory setting the serial address of Se0 is 1.

After changing the serial address of section "Se0" the ones that follow will take the next addresses.

N.B. Automatic configuration happens only during the first installation.

9. LIST OF PARAMETERS

SET Set Point (-999÷+999)

tPb Type of input (Pbr-id) Identifies if the input is a digital input or a measurement input.

ALU High temperature alarm: (0° + 999°C/°F) when temperature reaches SET+ALU the alarm is enabled, after the ALd delay time.

ALL Low temperature alarm: (0° + 999°C/°F) when temperature reaches SET-ALL the alarm is enabled, after the ALd delay time.

ALd Temperature alarm delay: (0÷120 min) time interval between the detection of an alarm condition and alarm signalling.

Ot Thermostat probe calibration: (-12.0÷+12.0°C/ -20÷+20°F) allows to adjust possible offset of the thermostat probe.

LCI Start of scale with current or voltage input: (999÷999). Adjustment of read out corresponding to 4mA or 0V input signal.

UCI End of scale with current or voltage input (999÷999). Adjustment of read out corresponding to 20mA or 10V input signal.

i1F Power supply input configuration:

Sta = status; ALL = alarm; dFr = defrost

i1P Power supply input polarity: ; CL: the input is activated if the power supply is present. oP: the input is activated if the power supply is not present; nP: the input is not present.

i2F Digital input (free voltage) configuration:

Sta = status; ALL = alarm; dFr = defrost

N.B. It is not possible to have both inputs configured as status or alarm

i2P Digital input (free voltage) polarity: ; CL: Active if closed. oP: Active if open; nP: the input is not present.

dd1 Power supply input delay: (0÷120min.) delay between the activation of the input and its signalling.

dd2 Digital input (free voltage) delay: (0÷120min.) delay between the activation of the input and its signalling.

nPS Pressure switch activation number: (0÷15) Number of activation of the pressure switch during "dd1" interval, before signalling the alarm event.

Adr Serial address (1÷247). Identifies the instrument when it is connected to a monitoring system.

10. XJP-REP & KB1 PRG & HOT KEY

The XJP has a connector on the front to connect the programming keyboard KB1 PRG which can be used to program the modules, the XJP-REP to display the input status or the "Hot Key".

10.1 USE OF THE PROGRAMMING "HOT KEY"

10.1.1 DOWNLOAD (From the "Hot Key" to the module)

If the programming key is plugged in, when the instrument is switched ON, the automatic DOWNLOAD of the parameters list from the "Hot Key" to the instrument will start. During this phase, the two Leds (RED and GREEN) are turned on fixed.

At the end of the data transfer phase the module displays the following messages:

Green Led "ON": right programming.
Red Led "ON" failed. programming.

If the programming has failed, the instrument has to be switch OFF and ON to repeat the operation or to start the normal regulation. (Starting to normal regulation remove the "Hot Key").

10.1.2 UPLOAD (From the module to the "Hot key")

The module can UPLQAD the parameters list from own E2 (internal memory) to the "Hot Key".

The programming keyboard has to be connected and the module switched ON. During the normal display, push "COPY" key for 5sec. until the label "uPL" will appear.

Pressing "SET" key, the module gets ready to the operation of UPLOAD.

Removing the keyboard and inserting the "Hot Key" within 30sec the UPLOAD will start.

At the end of the data transfer phase the module displays the following messages:

Green Led "ON": right programming.
Red Led "ON" failed. programming.

After removing the "Hot Key" the instrument waits 30sec.

If another "Hot key" is plugged in the UPLQAD will be done again.

11. INSTALLATION AND MOUNTING

XJP modules shall be mounted on an omega DIN rail (3). The ambient temperature range allowed for correct operation is 0 ÷ 60 °C. Avoid places subject to strong vibrations, corrosive gases, excessive dirt or humidity. The same recommendations apply to probes. Let air circulate by the cooling holes.

12. ELECTRICAL CONNECTIONS

The instruments are provided with screw terminal block to connect cables with a cross section up to 2,5 mm². Before connecting cables make sure the power supply complies with the instrument's requirements. Separate the input connection cables from the power supply cables, from the outputs and the power connections. Do not exceed the maximum current allowed on each relay, in case of heavier loads use a suitable external relay.

13. SERIAL COMMUNICATION

All the alarms, the states and the data measured by the modules XJP can be sent by serial RS485 to the XJ500 or a ModBUS-RTU compatible monitoring system.

14. TECHNICAL DATA

- Housing:** self extinguishing ABS.
- Case:** 4 DIN modules 70x85 mm; depth 61mm.
- Mounting:** DIN RAIL mounted in a omega (3) din rail .
- Connections:** Screw terminal block ≤ 2,5mm² wiring.
- Power supply:** 230Vac, ± 10% 50/60Hz (opt. 115Vac, ± 10% 50/60Hz; 24Vac. ± 10% 50/60Hz)
- Power absorption:** 3 VA max.
- Analogue inputs:**
- XJP60: 6 probes PTC or NTC or 6 inputs 4÷20mA or 0÷10V
- XJP30: 3 probes PTC or NTC or 6 inputs 4÷20mA or 0÷10V
- Inputs:**
- XJP60: 3 power supply inputs
- XJP30: 3 power supply inputs or 3 power supply inputs and 3 digital inputs free voltage.
- RS485 output :** RS485 serial output with ModBUS-RTU protocol.
- Data storing:** on the non-volatile memory (EEPROM).
- Operating temperature:** 0÷60 °C.
- Storage temperature:** -30÷85 °C.
- Relative humidity:** 20÷85% (no condensing)
- Measuring and regulation range:**
- PTC: -50÷150°C (-58÷302°F)
- NTC: -40÷110°C (-58÷230°F)
- or according to the probe
- Resolution:** 0,1 °C or 1 °F (selectable).
- Accuracy of the controller at 25°C:** ±0,3 °C ±1 digit

15. CONNECTIONS

15.1 XJP60D

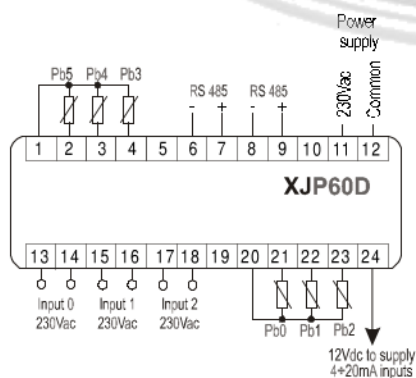

Pb3, Pb4 e Pb5 are configurable as digital inputs free voltage.

15.2 XJP30D WITH 3 POWER SUPPLY INPUTS

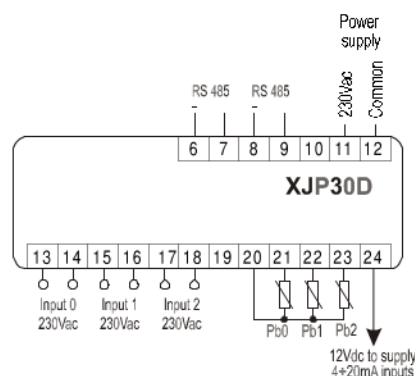

15.3 XJP30D WITH 3 POWER SUPPLY INPUTS AND 3 DIGITAL INPUTS FREE VOLTAGE

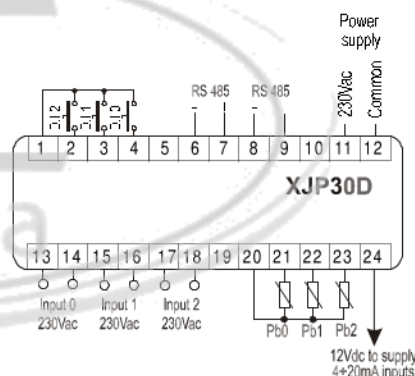

16. DEFAULT SETTING VALUES

GENERAL PARAMETERS

LABEL	Pr1 °C / °F	PARAMETERS	RANGE
dAO	1.0	Delay of temperature alarm at startup	0' + 23h 50'
EdA	30	Alarm delay at the end of defrost	0' + 120'
Pbc(**)	ptc or ntc	Type of probe	Ptc / ntc
rES	de/in	Resolution	in / de
CF	°C/°F	Temperature measurement unit	°C / °F
Ptb	---	Parameter table	---
rEL	---	Release software	---

SECTION PARAMETERS

SECTION PARAMETERS DEFAULT SETTING

LABEL	XJP60D						XJP30 with 3 power supply inputs			XJP30 with 3 power supply inputs and 3 inputs free voltage			PARAMETERS	RANGE
	SE 0	SE 1	SE 2	SE 3	SE 4	SE 5	SE 0	SE 1	SE 2	SE 0	SE 1	SE 2		
SEt	0	0	0	0	0	0	0	0	0	0	0	0	Set Point	-999 + 999
tPb	---	---	---	Pbr	Pbr	Pbr	---	---	---	Pbr	Pbr	Pbr	Type of input	Pbr = probe id = digital input
ALU	10	10	10	10	10	10	10	10	10	10	10	10	High temperature alarm	0° + 999°C/°F
ALL	10	10	10	10	10	10	10	10	10	10	10	10	Low temperature alarm	0° + 999°C/°F
ALd	15	15	15	15	15	15	15	15	15	15	15	15	Temperature alarm delay	0' + 120'
ot	0	0	0	0	0	0	0	0	0	0	0	0	Thermostat probe calibration	±12°C, ±20°F
LCI (*)	0	0	0	0	0	0	0	0	0	0	0	0	Lower current input	-999 + 999
UCI (*)	100	100	100	100	100	100	100	100	100	100	100	100	Higher current input	-999 + 999
i1F	dFr	dFr	dFr	---	---	---	dFr	dFr	dFr	dFr	dFr	dFr	Power supply input configuration	StA = Status ALL = Alarm dFr = Defrost
i1P	cL	cL	cL	---	---	---	cL	cL	cL	cL	cL	cL	Power supply input polarity	cL = closed oP = open nP = not present
i2F	---	---	---	StA	StA	StA	---	---	---	StA	StA	StA	Digital input (free voltage) configuration	StA = Status ALL = Alarm dFr = Defrost
i2P	---	---	---	cL	cL	cL	---	---	---	cL	cL	cL	Digital input (free voltage) polarity	cL = closed oP = open nP = not present
dd1	0	0	0	---	---	---	0	0	0	0	0	0	Power supply input delay	0' + 120'
dd2	---	---	---	0	0	0	---	---	---	0	0	0	Digital input (free voltage) delay	0' + 120'
nPS	0	0	0	---	---	---	0	0	0	0	0	0	Pressure switch activation number	0 + 15
Adr	1	2	3	4	5	6	1	2	3	1	2	3	Adr Serial address	0 + 247

(*) Parameters present only in 4+20mA or 0+10V models

(*) Parameter present only in PTC or NTC models

Dixell s.r.l. Z.I. Via dell'Industria, 27
32010 Pieve d'Alpago (BL) ITALY
tel. +39 - 0437 - 98 33 - fax +39 - 0437 - 98 93 13
E-mail:dixell@dixell.com - http://www.dixell.com